









Regulatory Speed Limit	50 km/h	60 km/h	70 km/h	80 km/h	90-100 km/h
1a Taper Length For Lane Closure	35 (1:10)	55 (1:15)	75 (1:20)	90 (1:25)	110 (1:30)
1b Taper Length For Shoulder Work on Where TCPs Used (Min. 3 Cones)	5	8	10	12	15
2 Maximum Distance Between Cones or Tubular Markers for 1a	10	10	10	10	10
3 Minimum Tangent Distance Between Tapers	30	60	90	120	150
4 Distance Between Construction Signs	40	60	80	100	150

**LEGENDS:**

-  SIGN STAND
-  DELINEATORS
-  TCP
-  ARROWBOARD TRUCK
-  POLE
-  REMOVE POLE
-  MANHOLE/SERVICE BOX
-  NEW BUILD
- 

**SCOPE:**  
- FIBRE OPTIC CABLE INSTALLATION

**DATES:** RENEWAL - SEE PERMIT BELOW

**HOURS:**  
- 7AM - 5PM

**DRAWING #:**  
- RPN 657531

- NOTES:**
- ALL TRAFFIC CONTROL DEVICES AND SIGNS TO COMPLY WITH LATEST MOTH MANUAL WORK ON ROADWAY.
  - MAINTAIN MINIMUM 3.2m LANE WIDTH
  - NOTIFY TRANSIT FOR CONSTRUCTION

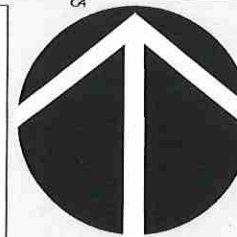

**PG 03**

**COMPANY:** DIXON NETWORKS CORPORATION

**CONTACT:** JOHNNY WOO  
**PHONE:** 604-940-8817 EXT. 238

**DIXON**  
NETWORKS CORPORATION